

SCHEDA TECNICA - TECHNICAL SHEET

RPI

Rondella per fissaggio pannelli isolanti
Washers for insulation panels

Rev: 02
Pag. 1/1

DATI TECNICI - TECHNICAL DATA

Cod. 61919

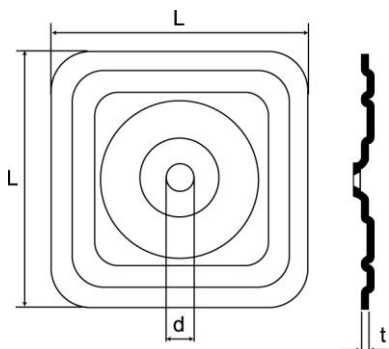

Cod. 61909 / 61915

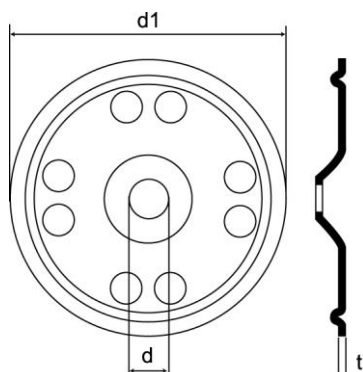

Cod. 61906 / 61918

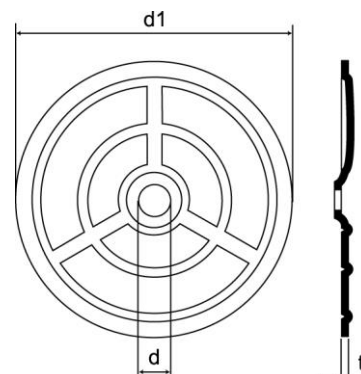

Cod. 61924

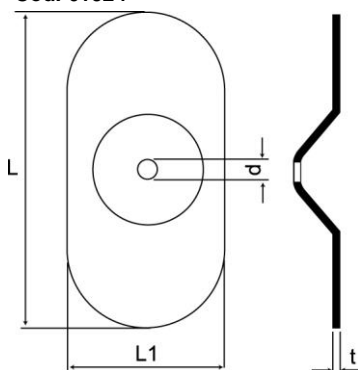

Cod. 61930

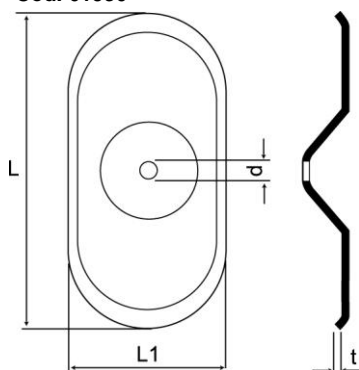

d = diametro foro
hole diameter
d1 = diametro esterno
external diameter
t = spessore rondella
washer thickness
L = dimensione rondella
washer dimension
L1 = dimensione rondella
washer dimension

d [mm]	d1 [mm]	t [mm]	L [mm]	L1 [mm]	Cod.
6	-	4/10	64	-	61919b64064
9	70	8/10	-	-	61909b70000
11,5	70	8/10	-	-	61915b70000
5	70	6/10	-	-	61906b70000
8	70	6/10	-	-	61918b70000
8,5	-	10/10	82	40	61924b40082
5,1	-	10/10	82	40	61930b40082

INSTALLAZIONE - INSTALLATION

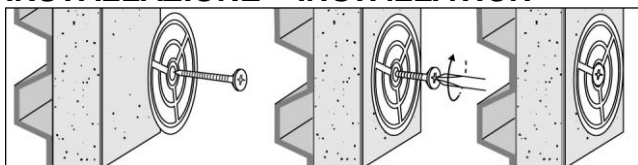

CARATTERISTICHE ANCORANTE - PRODUCT FEATURES

Tipo Type	Materiale Material	Rivestimento Coating
Rondella Washer	acciaio steel	lamiera zincata pre-zinc plated sheet
Rondella 61930 Washer 61930	aluzinc	